

INFORMATION

The ETA Ankerbolt is a zinc plated self tapping concrete screw with a hexagon flange head suitable for fixing into a variety of base materials and structures.

The product is suitable for application in dry internal conditions.

The undercutting action provides a positive anchorage with no expansion forces.

The variety of sizes and different embedment depths provide flexibility in selecting the appropriate anchor based on the fixture thickness.

Anchor Calculator Software can be used for detailed verifications based on EN 1992-4 or EOTA guidelines.

BASE MATERIAL

- Concrete C20/25 to C50/60
- Cracked/Non-Cracked Concrete
- Hollow Concrete Planks
- Solid Brickwork
- Concrete Block
- Natural Stone

FEATURES

- Undercutting Action
- Fast And Secure Installation
- Expansion Free
- Through Fixing
- Removable
- Adjustable
- High Performance with different embedment depths
- Zinc Plated
- Reaction To Fire Class A1
- Fire Resistant Loading

APPROVALS

European Technical Assessment



ETA-25/0815
Option 1 Structural Applications

ETA-25/0816
Multiple Use Non-Structural Applications



SOFTWARE



[Click here to download the software](#)

RELATED PRODUCTS



SDS+ Drill Bits



Hole Cleaning Pump

BOP1



ETA Socketbolt BZP



ETA Option 1
Hexagon Head
Ankerbolt BZP



ETA Ankerbolt
Stainless Steel



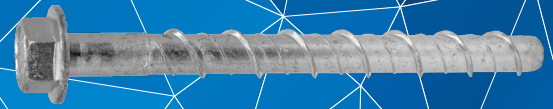

RANGE DATA

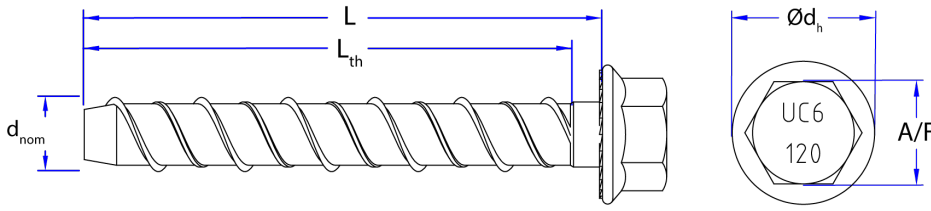

RANGE DATA							
Part Number	Drill Hole Diameter	Size of Thread	Anchor Length	Thread Length	Fixture Clearance Hole	Width Across Flats	Head Diameter
	d_o	d_{nom}	L	L_{th}	d_f	A/F	$\varnothing d_h$
	mm	mm	mm	mm	mm	mm	mm
JAB06/08050FETA	6	8	50	50	8	10	14
JAB06/08075FETA			75	75			
JAB06/08100FETA			100	100			
JAB06/08130FETA			130				
JAB08/10060FETA	8	10	60	60	11	13	18
JAB08/10080FETA			80	80			
JAB08/10100FETA			100	100			
JAB08/10130FETA			130				
JAB08/10150FETA			150				
JAB10/12060FETA	10	12	60	60	13	15	22
JAB10/12075FETA			75	75			
JAB10/12100FETA			100	105			
JAB10/12130FETA			130				
JAB10/12150FETA			150				
JAB12/14075FETA	12	14	75	75	15	16	26.5
JAB12/14100FETA			100	100			
JAB12/14130FETA			130	115			
JAB12/14150FETA			150				
JAB12/14200FETA			200				
JAB14/16100FETA	14	16	100	100	17	18	30.5
JAB14/16130FETA			130	125			
JAB14/16150FETA			150				
JAB14/16200FETA			200				
JAB16/18110FETA	16	18	110	110	19	20	35
JAB16/18125FETA			125	130			
JAB16/18150FETA			150				
JAB16/18200FETA			200				



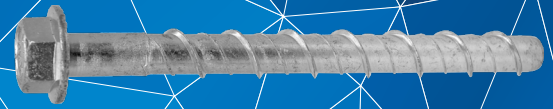

INSTALLATION INTO CONCRETE

Refer to the ETA approvals available on the JCP website for complete installation instructions and parameters, including options with or without cleaning or fixture thickness adjustment.

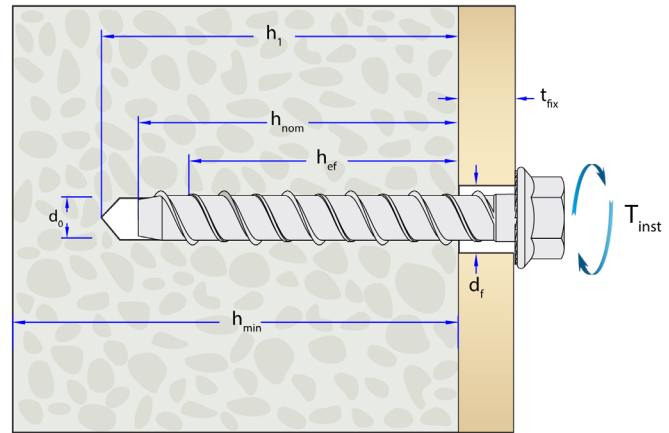

Installation Parameters in Concrete

Part Number	Drill Hole Diameter (d _o)	Reduced Embedment			Standard Embedment			Deep Embedment			Fixture Clearance Hole (d _f)	Impact Driver Maximum Torque (T _{imp,max})	Tightening Torque (T _{inst})	Minimum Spacing (s _{min})	Minimum Edge Distance (c _{min})
		Min Hole Depth (h ₁)	Embedment Depth (h _{nom})	Max Fixture Thickness (t _{fix})	Min Hole Depth (h ₁)	Embedment Depth (h _{nom})	Max Fixture Thickness (t _{fix})	Min Hole Depth (h ₁)	Embedment Depth (h _{nom})	Max Fixture Thickness (t _{fix})					
		mm	mm	mm	mm	mm	mm	mm	mm	mm					
JAB06/08050FETA	6	45**	35**	15**	50	45	5	N/A			8	250	10	35*	35*
JAB06/08075FETA				40**			30	20							
JAB06/08100FETA				65**			55	45							
JAB06/08130FETA				85			75								
JAB08/10060FETA	8	N/A	N/A	60	50	75	10	N/A			11	250	20	35	35
JAB08/10080FETA							30	15							
JAB08/10100FETA							50	35							
JAB08/10130FETA							80	65							
JAB08/10150FETA							100	85							
JAB10/12060FETA	10	65	55	75	65	95	5	N/A			13	350	30	40	40
JAB10/12075FETA							20	10							
JAB10/12100FETA							45	35	15						
JAB10/12130FETA							75	65	45						
JAB10/12150FETA							95	85	65						
JAB12/14075FETA	12	75	65	95	85	110	10	N/A			15	350	50	50	50
JAB12/14100FETA							35	15							
JAB12/14130FETA							65	45	30						
JAB12/14150FETA							85	65	50						
JAB12/14200FETA							135	115	100						

* If the drilled holes have been cleaned during the installation.

** For Multiple-Use Non-Structural applications



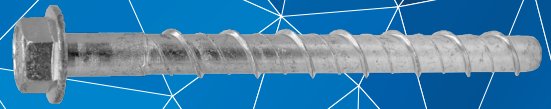

Installation Parameters in Concrete

Part Number	Drill Hole Diameter (d _p)	Reduced Embedment			Standard Embedment			Deep Embedment			Fixture Clearance Hole (d _f)	Impact Driver Maximum Torque (T _{imp,max})	Tightening Torque (T _{inst})	Minimum Spacing (s _{min})	Minimum Edge Distance (c _{min})
		Min Hole Depth* (h _p)	Embedment Depth (h _{nom})	Max Fixture Thickness (t _{fix})	Min Hole Depth* (h _p)	Embedment Depth (h _{nom})	Max Fixture Thickness (t _{fix})	Min Hole Depth* (h _p)	Embedment Depth (h _{nom})	Max Fixture Thickness (t _{fix})					
		mm	mm	mm	mm	mm	mm	mm	mm	mm					
JAB14/16100FETA	14	95	85	15	N/A			N/A			17	350	60	60	60
JAB14/16130FETA				45	110	100	30	125	115	15					
JAB14/16150FETA				65			50			35					
JAB14/16200FETA				115			100			85					
JAB16/18110FETA	16	N/A	N/A	115	100	10	N/A			19	350	80	70	70	
JAB16/18125FETA						25	135	120	5						
JAB16/18150FETA						50			30						
JAB16/18200FETA						100			80						

* If the drilled holes have been cleaned during the installation.

INSTALLATION INSTRUCTIONS INTO SOLID CONCRETE

Click on the QR code or scan it to watch the video

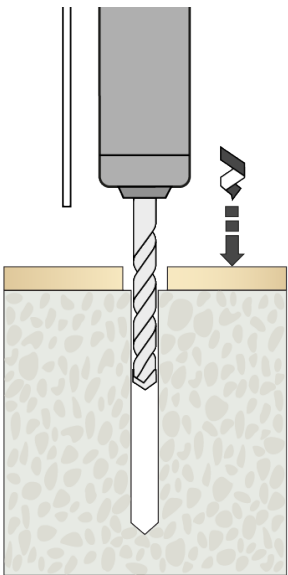

-Position fixture and drill correct diameter hole to corresponding depth by using the rotary hammer drilling mode

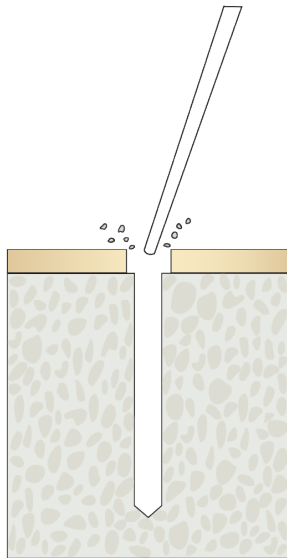

-Clean hole by blowing three times to remove drilling debris and dust

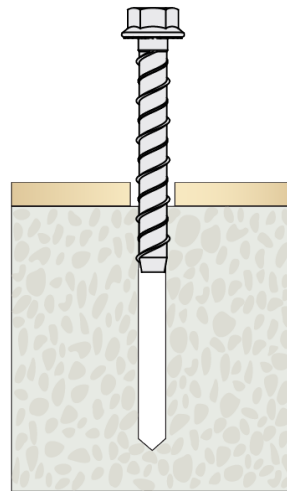

-Insert anchor through fixture into concrete using electrical impact driver Bosch GD18E or Makita 6905H. Other suitable impact driver with equivalent force and performance may be used.

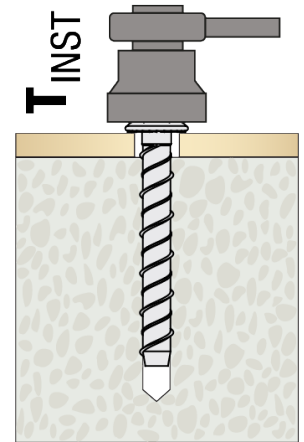

-Tighten with torque wrench to recommended value.

Ensure the head of anchors to be in contact with the fixture and undamaged. Further turning of anchors must not be possible.



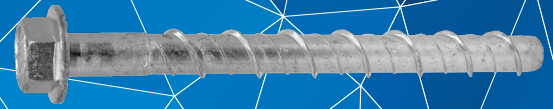

PERFORMANCE DATA FOR STRUCTURAL APPLICATIONS (NON-CRACKED CONCRETE)

Anchor performance data apply to a single anchor without spacing or edge effects, and not under combined shear and tension. For full verification, refer to ETA approval or the Anchor Calculation Program.

Performance Data (C20/25 non-cracked concrete) Reduced Embedment

Drill Hole Diameter	Embedment Depth	Minimum Concrete Thickness	Characteristic Resistance		Design Resistance		Recommended Resistance	
			Tensile (N_{Rk})	Shear (V_{Rk})	Tensile (N_{Rd})	Shear (V_{Rd})	Tensile (N_{Rec})	Shear (V_{Rec})
d_0	h_{nom}	h_{min}	kN	kN	kN	kN	kN	kN
6	35		See tables for non-structural application					
8			Not assessed					
10	55	80	9	11	4.2	7.3	3.0	5.2
12	65	100	10	14.3	4.7	9.5	3.4	6.8
14	85	120	19	45.7	10.5	30.4	7.5	21.7
16			Not assessed					

Performance Data (C20/25 non-cracked concrete) Standard Embedment

Drill Hole Diameter	Embedment Depth	Minimum Concrete Thickness	Characteristic Resistance		Design Resistance		Recommended Resistance	
			Tensile (N_{Rk})	Shear (V_{Rk})	Tensile (N_{Rd})	Shear (V_{Rd})	Tensile (N_{Rec})	Shear (V_{Rec})
d_0	h_{nom}	h_{min}	kN	kN	kN	kN	kN	kN
6	45	80	1	8.0	0.4	5.3	0.3	3.8
8	50	80	7.5	9.7	3.5	6.5	2.5	4.6
10	65	90	11	14.8	6.1	9.9	4.3	7.0
12	85	120	15	46.8	8.3	31.2	5.9	22.2
14	100	150	28	60.1	15.5	40	11.1	28.5
16	100	150	28	58.8	15.5	39.2	11.1	28.0

Performance Data (C20/25 non-cracked concrete) Deep Embedment

Drill Hole Diameter	Embedment Depth	Minimum Concrete Thickness	Characteristic Resistance		Design Resistance		Recommended Resistance	
			Tensile (N_{Rk})	Shear (V_{Rk})	Tensile (N_{Rd})	Shear (V_{Rd})	Tensile (N_{Rec})	Shear (V_{Rec})
d_0	h_{nom}	h_{min}	kN	kN	kN	kN	kN	kN
6	55	80	7.5	12.6	4.1	8.4	2.9	6
8	65	80	11	15.8	6.1	10.5	4.3	7.5
10	85	120	20	31.2	11.1	20.8	7.9	14.8
12	100	150	20	40.4	11.1	26.9	7.9	19.2
14	115	150	28	56	15.5	37.3	11.1	26.6
16	120	150	36	73.4	20	48.9	14.2	34.9



For variations in structure thickness, reduced spacing and edge calculations download the free **Anchor Calculation Program** from www.jcpfixings.co.uk



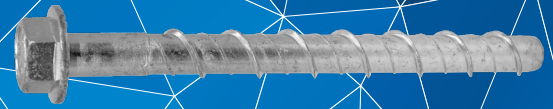

PERFORMANCE DATA FOR STRUCTURAL APPLICATIONS (CRACKED CONCRETE)

Anchor performance data apply to a single anchor without spacing or edge effects, and not under combined shear and tension. For full verification, refer to ETA approval or the Anchor Calculation Program.

Performance Data* (C20/25 cracked concrete) Reduced Embedment

Drill Hole Diameter	Embedment Depth	Minimum Concrete Thickness	Characteristic Resistance		Design Resistance		Recommended Resistance	
			Tensile (N_{Rk})	Shear (V_{Rk})	Tensile (N_{Rd})	Shear (V_{Rd})	Tensile (N_{Rec})	Shear (V_{Rec})
d_0	h_{nom}	h_{min}	kN	kN	kN	kN	kN	kN
6	35		See tables for non-structural application					
8			Not assessed					
10	55	80	4.5	7.7	2.1	5.1	1.5	3.6
12	65	100	7	10	3.3	6.7	2.3	4.7
14	85	120	14	32	7.7	21.3	5.5	15.2
16			Not assessed					

Performance Data* (C20/25 cracked concrete) Standard Embedment

Drill Hole Diameter	Embedment Depth	Minimum Concrete Thickness	Characteristic Resistance		Design Resistance		Recommended Resistance	
			Tensile (N_{Rk})	Shear (V_{Rk})	Tensile (N_{Rd})	Shear (V_{Rd})	Tensile (N_{Rec})	Shear (V_{Rec})
d_0	h_{nom}	h_{min}	kN	kN	kN	kN	kN	kN
6	45	80	Not assessed					
8	50	80	2.5	6.8	1.1	4.5	0.8	3.2
10	65	90	9	10.3	5.0	6.9	3.5	4.9
12	85	120	11	32.8	6.1	21.8	4.3	15.5
14	100	150	21	42	11.6	28	8.3	20
16	100	150	15	41.2	8.3	27.4	5.9	19.5

Performance Data* (C20/25 cracked concrete) Deep Embedment

Drill Hole Diameter	Embedment Depth	Minimum Concrete Thickness	Characteristic Resistance		Design Resistance		Recommended Resistance	
			Tensile (N_{Rk})	Shear (V_{Rk})	Tensile (N_{Rd})	Shear (V_{Rd})	Tensile (N_{Rec})	Shear (V_{Rec})
d_0	h_{nom}	h_{min}	kN	kN	kN	kN	kN	kN
6	55	80	4	9.04	2.2	5.0	1.5	3.5
8	65	80	8.5	11.1	4.7	7.4	3.3	5.2
10	85	120	13	31.2	7.2	20.8	5.1	13.3
12	100	150	15	40.4	8.3	26.9	5.9	19.2
14	115	150	24	53.9	13.3	35.9	9.5	25.6
16	120	150	24	56.8	13.3	37.9	9.5	27



For variations in structure thickness, reduced spacing and edge calculations download the free **Anchor Calculation Program** from www.jcpfixings.co.uk





Influence Of Concrete Strength for Cracked and Non-cracked Concrete (Reduced / Standard / Deep Installation)

Concrete strength		C20/25			C30/37			C40/50			C50/60		
Cylinder	N/mm ²	20			30			40			50		
Cube	N/mm ²	25			37			50			60		
Embedment Depth		Reduced	Standard	Deep	Reduced	Standard	Deep	Reduced	Standard	Deep	Reduced	Standard	Deep
Cylinder	N/mm ²	20			30			40			50		
Cube	N/mm ²	25			37			50			60		
Drill Diameter (mm)	6	1.0	-	1.09	1.10	-	1.16	1.18	-	1.21	1.25		
	8	1.0	-	1.06	1.09	-	1.11	1.17	-	1.15	1.23		
	10	1.0	1.06	1.07	1.08	1.11	1.13	1.13	1.14	1.18	1.18		
	12	1.0	1.06	1.08	1.06	1.11	1.14	1.10	1.15	1.18	1.13		
	14	1.0	1.07	1.07	1.07	1.11	1.11	1.12	1.15	1.15	1.16		
	16	1.0	-	1.08	1.09	-	1.14	1.16	-	1.19	1.22		

PERFORMANCE DATA FOR MULTIPLE USE NON STRUCTURAL APPLICATIONS (CRACKED- NON NON CRACKED CONCRETE)

Performance Data* (C20/25 to C50/60 Cracked and Non-Cracked Concrete)

Drill Hole Diameter	Embedment Depth	Minimum Concrete Thickness	Characteristic Resistance		Design Resistance		Recommended Resistance	
			Tensile (N _{Rk})	Shear (V _{Rk})	Tensile (N _{Rd})	Shear (V _{Rd})	Tensile (N _{Rec})	Shear (V _{Rec})
d ₀	h _{nom}	h _{min}	kN	kN	kN	kN	kN	kN
6	35	80	1	1	0.55	0.55	0.39	0.39
	55	80	4	4	2.2	2.2	1.5	1.5

* Important notes:

- Fasteners subject to static and quasi-static loads.
- Performance data stated for a single anchor, without the effect of spacing and edge distances. The influence of these parameters must be verified where applicable.
- Minimum concrete thickness, hole diameter, and embedment depth shall correspond to the dimensions stated in this document.
- Concrete strength class C20/25 is assumed.
- Drill holes produced using rotary hammer drilling, unless otherwise noted.
- Installation carried out strictly in accordance with the product's Installation Instructions and performed by a trained operator.
- Characteristic and design resistances derived from JCP internal technical data.
- Design resistances are calculated from characteristic values using the appropriate partial safety factors corresponding to the decisive failure mode.
- The Recommended Resistance is calculated using an additional safety factor (v_{Add}) equal to 1.4.
- Performance data is valid for shear loading without a lever arm; installations involving a lever arm require additional verifications.
- Performance data is not valid for combined tensile and shear loading; where combined loading occurs, further checks shall be performed.
- When concrete-related strength factors are applied, ensure that the resulting resistance value does not exceed the steel design resistance.
- For project-specific assessments or conditions not explicitly covered, download the JCP Anchor Calculation Program.



For variations in structure thickness, reduced spacing and edge calculations download the free **Anchor Calculation Program** from www.jcpfixings.co.uk



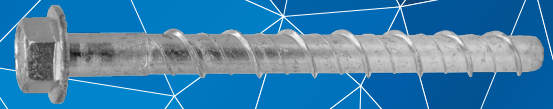

FIRE RESISTANCE DATA



Fire Resistance Data (C20/25 to C50/60 Cracked or Non-Cracked concrete) Reduced Embedment*

Drill Hole Diameter	Embedment Depth	Minimum Concrete Thickness	Design Resistance				Recommended Resistance			
			Tensile ($N_{Rd,fi}$) or Shear ($V_{Rd,fi}$) (kN)				Tensile ($N_{Rec,fi}$) or Shear ($V_{Rec,fi}$) (kN)			
mm	mm	mm	30min (R30)	60min (R60)	90min (R90)	120min (R120)	30min (R30)	60min (R60)	90min (R90)	120min (R120)
6	35		N/A							
8			N/A							
10	55	80	1.03	0.89	0.69	0.55	0.74	0.64	0.49	0.39
12	65	100	1.25	1.52	1.32	1.01	1.44	1.09	0.94	0.72
14	85	120	2.8	2.1	1.82	1.4	2.00	1.50	1.30	1.00
16			N/A							

Fire Resistance Data (C20/25 to C50/60 Cracked or Non-Cracked concrete) Standard Embedment*

Drill Hole Diameter	Embedment Depth	Minimum Concrete Thickness	Design Resistance				Recommended Resistance			
			Tensile ($N_{Rd,fi}$) or Shear ($V_{Rd,fi}$) (kN)				Tensile ($N_{Rec,fi}$) or Shear ($V_{Rec,fi}$) (kN)			
mm	mm	mm	30min (R30)	60min (R60)	90min (R90)	120min (R120)	30min (R30)	60min (R60)	90min (R90)	120min (R120)
6	45	80	N/A							
8	50	80	0.42	0.38	0.3	0.21	0.30	0.27	0.21	0.15
10	65	90	1.03	0.89	0.69	0.55	0.74	0.64	0.49	0.39
12	85	120	2.02	1.52	1.32	1.01	1.44	1.09	0.94	0.72
14	100	150	2.8	2.1	1.82	1.4	2.00	1.50	1.30	1.00
16	100	150	3.7	2.78	2.41	1.85	2.64	1.99	1.72	1.32

Fire Resistance Data (C20/25 to C50/60 Cracked or Non-Cracked concrete) Deep Embedment*

Drill Diam	Embedment Depth	Minimum Concrete Thickness	Design Resistance				Recommended Resistance			
			Tensile ($N_{Rd,fi}$) or Shear ($V_{Rd,fi}$) (kN)				Tensile ($N_{Rec,fi}$) or Shear ($V_{Rec,fi}$) (kN)			
mm	mm	mm	30min (R30)	60min (R60)	90min (R90)	120min (R120)	30min (R30)	60min (R60)	90min (R90)	120min (R120)
6	55	80	0.22	0.2	0.16	0.11	0.16	0.14	0.11	0.08
8	65	80	0.42	0.38	0.3	0.21	0.30	0.27	0.21	0.15
10	85	120	1.03	0.89	0.69	0.55	0.74	0.64	0.49	0.39
12	100	150	2.02	1.52	1.32	1.01	1.44	1.09	0.94	0.72
14	115	150	2.8	2.1	1.82	1.4	2.00	1.50	1.30	1.00
16	120	150	3.7	2.78	2.41	1.85	2.64	1.99	1.72	1.32

* The determination covers anchors with a fire attack from one side only. If the fire attack is from more than one side, the design method may be taken only, if the edge distance of the anchor is $c \geq 300$ mm and $\geq 2 h_{ef}$.



For variations in structure thickness, reduced spacing and edge calculations download the free **Anchor Calculation Program** from www.jcpfixings.co.uk



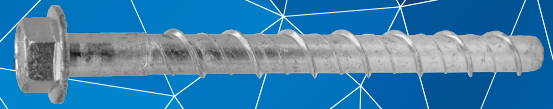

INSTALLATION INTO HOLLOW CONCRETE PLANKS

Refer to ETA approvals available on website for more complete installation instruction and parameters with or without cleaning or with fixture thickness adjustment.

Core width $w \leq 180$

Core distance $l_c \geq 210$

Prestressing steel distance $l_p \geq 210$

Distance between anchor position and prestressing steel $a_p \geq 50$

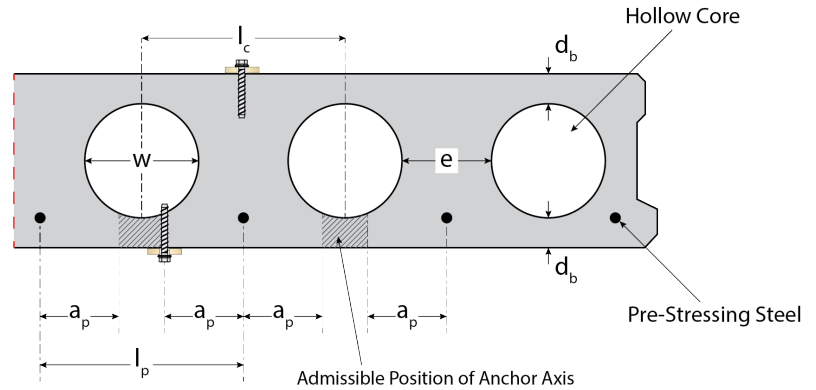

Installation Parameters In Hollow Concrete Planks

Part Number	Drill Hole Diameter	Min Hole Depth	Embedment Depth	Max Fixture Thickness	Fixture Clearance Hole	Impact Driver Maximum Torque	Tightening Torque	Minimum Spacing	Minimum Edge Distance
	d_0	h_1	h_{nom}	t_{fix}	d_f	$T_{imp,max}$	T_{inst}	s_{min}	c_{min}
	mm	mm	mm	mm	mm	Nm	Nm	mm	mm
JAB06/08050FETA	6	45	35	15	8	250	10	80	40
JAB06/08075FETA				40					
JAB06/08100FETA				65					
JAB06/08130FETA				95					

PERFORMANCE DATA FOR MULTIPLE USE NON STRUCTURAL APPLICATIONS (HOLLOW CONCRETE PLANKS)

Performance Data* (C40/50 to C50/60 Hollow Concrete Planks)

Drill Hole Diameter	Embedment Depth	Minimum Concrete Thickness	Characteristic Resistance		Design Resistance		Recommended Resistance	
			Tensile (N_{Rk})	Shear (V_{Rk})	Tensile (N_{Rd})	Shear (V_{Rd})	Tensile (N_{Rrec})	Shear (V_{Rrec})
d_0	h_{nom}	d_b	kN	kN	kN	kN	kN	kN
6	35	35	4.5	4.5	2.5	2.5	1.7	1.7

* Important notes:

- Fasteners subject to static and quasi-static loads.
- Performance data stated for a single anchor, without the effect of spacing and edge distances. The influence of these parameters must be verified where applicable.
- Minimum concrete thickness, hole diameter, and embedment depth shall correspond to the dimensions stated in this document.
- Concrete strength class C20/25 is assumed.
- Drill holes produced using rotary hammer drilling, unless otherwise noted.
- Installation carried out strictly in accordance with the product's Installation Instructions and performed by a trained operator.
- Characteristic and design resistances derived from JCP internal technical data.
- Design resistances are calculated from characteristic values using the appropriate partial safety factors corresponding to the decisive failure mode.
- The Recommended Resistance is calculated using an additional safety factor (γ_{Add}) equal to 1.4.
- Performance data is valid for shear loading without a lever arm; installations involving a lever arm require additional verifications.
- Performance data is not valid for combined tensile and shear loading; where combined loading occurs, further checks shall be performed.
- When concrete-related strength factors are applied, ensure that the resulting resistance value does not exceed the steel design resistance.
- For project-specific assessments or conditions not explicitly covered, download the JCP Anchor Calculation Program.



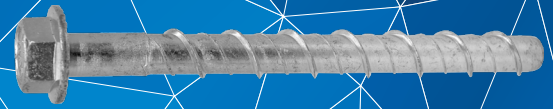

INSTALLATION INSTRUCTIONS INTO HOLLOW CONCRETE PLANKS

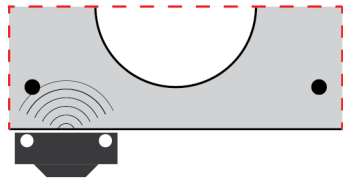

-Search for the position of the reinforcement

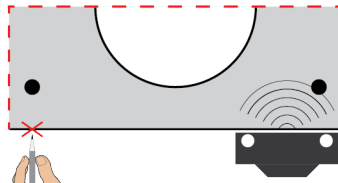

-Mark the position of the reinforcement and Search for the other position of the reinforcement

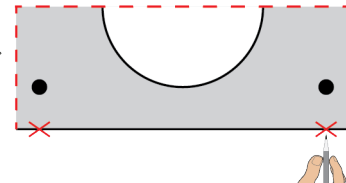

-Mark the position of the reinforcement

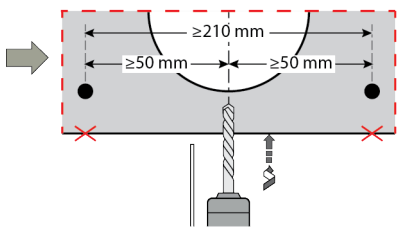

-Drill correct diameter hole to corresponding depth while maintaining the required distances

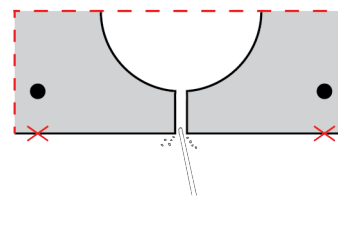

-Clean hole by blowing to remove drilling debris and dust

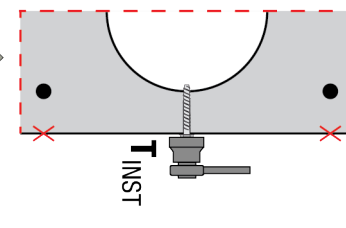

-Insert anchor through fixture into concrete using electrical impact driver Bosch GD18E or Makita 6905H. Other suitable impact driver with equivalent force and performance may be used. Ensure the head of anchors to be in contact with the fixture and undamaged. Further turning of anchors must not be possible.

SUPPLEMENTARY DATA

Steel Failure

Drill Hole Diameter	Tensile Resistance									Shear Resistance								
	Characteristic Resistance			Design Resistance			Recommended Resistance			Characteristic Resistance			Design Resistance			Recommended Resistance		
d_0	$N_{Rk,s}$			$N_{Rd,s}$			$N_{Rec,s}$			$V_{Rk,s}$			$V_{Rd,s}$			$V_{Rec,s}$		
mm	kN			kN			kN			kN			kN			kN		
Embedment Depth	Reduced	Standard	Deep	Reduced	Standard	Deep	Reduced	Standard	Deep	Reduced	Standard	Deep	Reduced	Standard	Deep	Reduced	Standard	Deep
8	38.2			25.5			18.2			-	16.3	20.3	-	10.9	13.5	-	7.8	9.7
10	61.8			41.2			29.4			27.6	31.2	31.2	18.4	20.7	20.7	13.1	14.9	14.9
12	80.9			53.9			38.5			34.5	40.4	40.4	23	26.9	26.9	16.4	19.2	19.2
14	112.0			74.7			53.3			56.0	56.0	56.0	37.3	37.3	37.3	26.6	26.6	26.6
16	148.1			98.7			70.5			-	71.5	73.4	-	47.7	48.9	-	34.0	34.9

