



INFORMATION

The torque controlled Throughbolt is a Hot Dipped Galvanised through fixing for use in non-cracked concrete and normal applications such as:

- Metal constructions
- Facades
- Gates
- Guard Rails and Temporary Barriers
- Temporary site equipments' anchoring
- Fencing
- Warehouse Shelving
- Temporary Signs and posts
- Brackets
- MEP support systems
- Railing

BASE MATERIAL

- Concrete C20/25 to C50/60
- Non-Cracked Concrete

FEATURES

- High Performance
- Hot dipped Galvanized according to EN ISO 1461
- Increased Corrosion Resistance vs BZP version
- Wide Range Of Sizes
- Fast And Secure Installation
- Through Fixing
- Close Spacing And Edge Distance
- Performance Data for Different Embedment Depth
- Reaction To Fire Class A1

APPROVALS

European Technical Assessment



ETA-07/0332
Option 7 Structural Applications

SOFTWARE



[Click here to download the software](#)

RELATED PRODUCTS



SDS+ Drill Bits



Hole Cleaning Pump

BOP1



Option 7 Throughbolt
BZP



Option 7 Throughbolt
A4 Stainless Steel



Option 1 Throughbolt
BZP



Option 1 Throughbolt
A4 Stainless Steel





RANGE DATA

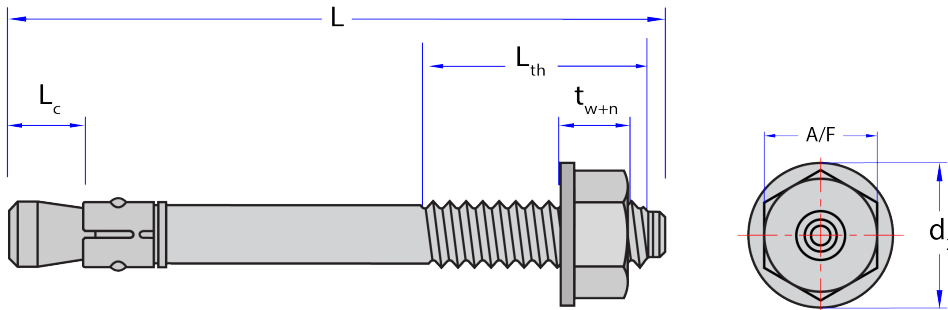

RANGE DATA

Part Number	Size of Thread	Total Length	Thread Length	Cone Length	Washer and Nut Thickness	Width Across Flats	Washer Outer diameter
	mm	(L) mm	(L _{th}) mm	(L _c) mm	(t _{w+n}) mm	(A/F) mm	(d ₂) mm
ATG08075	M8	75	40	12	8.1	13	16
ATG08095		95	60				
ATG08120		120	85				
ATG10070	M10	70	30	14	10	17	20
ATG10085		85	40				
ATG10105		105	60				
ATG10125		125	80				
ATG12095	M12	95	50	17	12.5	19	24
ATG12110		110	65				
ATG12145		145	100				
ATG12180		180	100				
ATG16115	M16	115	60	20	16	24	30
ATG16130		130	70				
ATG16150		150	90				
ATG16200		200	110				
ATG20180	M20	180	70	21	19	30	37
ATG20220		220	70				
ATG20280		280	70				





INSTALLATION INTO CONCRETE

Refer to the ETA approval available on the JCP website for complete installation instructions and parameters including minimum spacing and edge distances for different installation configuration.

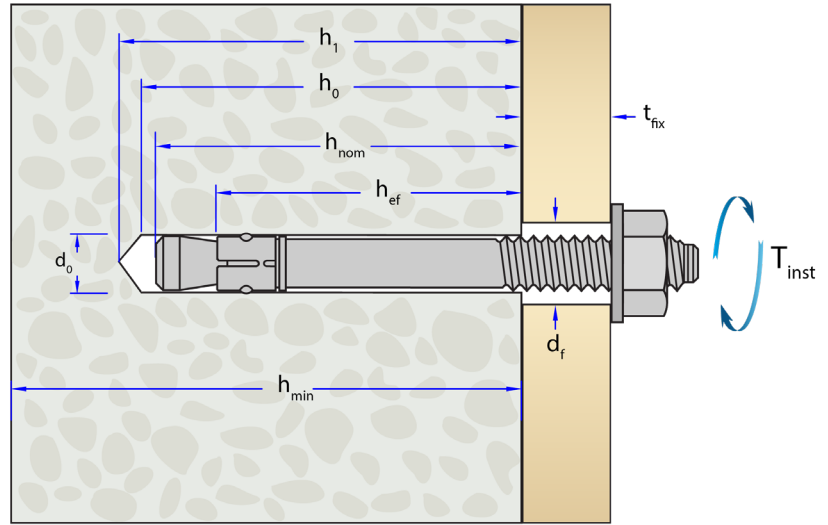

Installation Parameters in Concrete

Part Number	Drill Hole Diameter (d_0)	Reduced Embedment				Standard Embedment				Deep Embedment				Fixture Clearance Hole (d_f)	Tightening Torque (T_{inst})
		Min Hole Depth (h_1)	Embedment Depth (h_{nom})	Anchorage Depth (h_{ef})	Max Fixture Thickness (t_{fix})	Min Hole Depth (h_1)	Embedment Depth (h_{nom})	Anchorage Depth (h_{ef})	Max Fixture Thickness (t_{fix})	Min Hole Depth (h_1)	Embedment Depth (h_{nom})	Anchorage Depth (h_{ef})	Max Fixture Thickness (t_{fix})		
		mm	mm	mm	mm	mm	mm	mm	mm	mm	mm	mm	mm		
ATG08075	8	55	47	35	19	65	56	44	10	N/A				9	15
ATG08095					39				30	91	82	70	4		
ATG08120					64				55						
ATG10070	10	65	56	42	1	N/A				N/A				12	30
ATG10085					16	10	N/A								
ATG10105					36	70	62	48	30	N/A					
ATG10125					56	50	102	94	80	18					
ATG12095	12	75	67	50	13	N/A				N/A				14	40
ATG12110					30	15	N/A								
ATG12145					65	90	82	65	50	125	117	100	15		
ATG12180					100	85	50								
ATG16115	16	95	84	64	13	N/A				N/A				18	90
ATG16130					28	10	N/A								
ATG16150					48	110	102	82	30	N/A					
ATG16200					98	80	148	140	120	42					
ATG20180	20	110	99	78	57	130	121	100	35	145	136	115	20	22	120
ATG20220					97				75				60		
ATG20280					157				135				120		





INSTALLATION INSTRUCTIONS INTO SOLID CONCRETE

Click on the QR code or scan it to watch the video

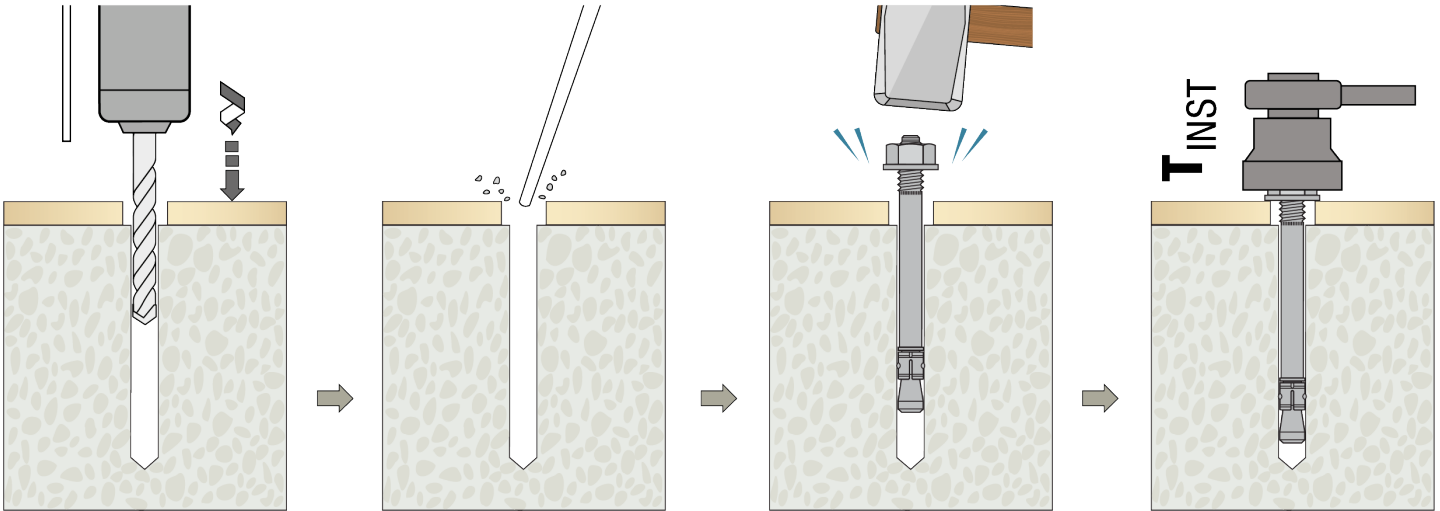

-Position fixture and drill correct diameter hole to corresponding depth

-Clean hole by blowing to remove drilling debris and dust

-Insert anchor through fixture into concrete and lightly hammer into concrete

-Tighten with torque wrench to recommended torque



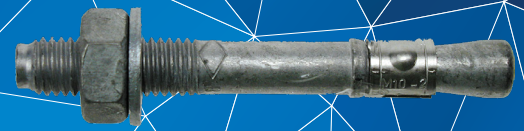

PERFORMANCE DATA FOR STRUCTURAL APPLICATIONS (NON-CRACKED CONCRETE)

Anchor performance data apply to a single anchor without spacing or edge effects, and not under combined shear and tension. For full verification, refer to ETA approval or the Anchor Calculation Program.

Performance Data (C20/25 non-cracked concrete) Reduced Embedment

Size of Thread	Embedment Depth	Minimum Concrete Thickness	Characteristic Resistance		Design Resistance		Recommended Resistance	
			Tensile (N_{Rk})	Shear (V_{Rk})	Tensile (N_{Rd})	Shear (V_{Rd})	Tensile (N_{Rec})	Shear (V_{Rec})
mm	h_{nom}	h_{min}	kN	kN	kN	kN	kN	kN
M8*	47	80	10.2	11	6.7	8.8	4.8	6.2
M10	56	100	13.4	17	8.9	13.6	6.3	9.7
M12	67	100	17.4	25	11.6	20	8.2	14.2
M16	84	130	25.2	44	16.8	33	12.00	23.6
M20	99	160	33.9	69	22.6	51.8	16.1	37.0

* Use is restricted to anchorage of indeterminate structural components and subject to internal exposure conditions.

Performance Data (C20/25 non-cracked concrete) Standard Embedment

Size of Thread	Embedment Depth	Minimum Concrete Thickness	Characteristic Resistance		Design Resistance		Recommended Resistance	
			Tensile (N_{Rk})	Shear (V_{Rk})	Tensile (N_{Rd})	Shear (V_{Rd})	Tensile (N_{Rec})	Shear (V_{Rec})
mm	h_{nom}	h_{min}	kN	kN	kN	kN	kN	kN
M8	56	100	13	11	8.67	8.8	6.1	6.2
M10	62	100	16.4	17	10.9	13.6	7.8	9.7
M12	82	130	25.8	25	17.2	20	12.2	14.2
M16	102	170	35.2	44	23.4	33	16.7	23.6
M20	121	200	49.2	69	32.8	51.8	23.4	37

Performance Data (C20/25 non-cracked concrete) Deep Embedment

Size of Thread	Embedment Depth	Minimum Concrete Thickness	Characteristic Resistance		Design Resistance		Recommended Resistance	
			Tensile (N_{Rk})	Shear (V_{Rk})	Tensile (N_{Rd})	Shear (V_{Rd})	Tensile (N_{Rec})	Shear (V_{Rec})
mm	h_{nom}	h_{min}	kN	kN	kN	kN	kN	kN
M8	82	126	13	11	8.67	8.8	6.1	6.2
M10	94	132	16.4	17	10.9	13.6	7.8	9.7
M12	117	165	26	25	17.3	20	12.3	14.2
M16	140	208	40	44	26.6	33	19	23.6
M20	136	215	55	69	36.6	51.8	26.1	37



For variations in structure thickness, reduced spacing and edge calculations download the free **Anchor Calculation Program** from www.jcpfixings.co.uk



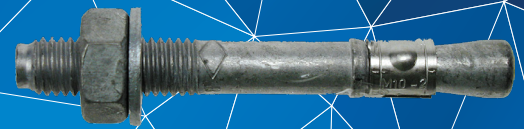

SUPPLEMENTARY DATA

Steel Failure						
Drill Hole Diameter	Tensile Resistance			Shear Resistance		
	Characteristic Resistance	Design Resistance	Recommended Resistance	Characteristic Resistance	Design Resistance	Recommended Resistance
d_0	$N_{Rk,s}$	$N_{Rd,s}$	$N_{Rec,s}$	$V_{Rk,s}$	$V_{Rd,s}$	$V_{Rec,s}$
mm	kN	kN	kN	kN	kN	kN
M8	15.3	10.2	7.2	11	8.8	6.2
M10	26	17.3	12.3	17	13.6	9.7
M12	35	29.3	20.9	25	20	14.2
M16	65	40.6	29	44	33	23.6
M20	107	66.8	47.7	69	51.8	37

Influence Of Concrete Strength f for Non-cracked Concrete (Reduced / Standard / Deep Installation)					
Concrete strength		C20/25	C30/37	C40/50	C50/60
Cylinder	N/mm ²	20	30	40	50
Cube	N/mm ²	25	37	50	60
Drill Diameter (mm)	M8	1.0	1.22	1.41	1.58
	M10	1.0	1.22	1.41	1.58
	M12	1.0	1.22	1.41	1.58
	M16	1.0	1.14	1.25	1.35
	M20	1.0	1.22	1.41	1.58

* Important notes:

- Fasteners subject to static and quasi-static loads.
- Performance data stated for a single anchor, without the effect of spacing and edge distances. The influence of these parameters must be verified where applicable.
- Minimum concrete thickness, hole diameter, and embedment depth shall correspond to the dimensions stated in this document.
- Concrete strength class C20/25 is assumed.
- Drill holes produced using rotary hammer drilling, unless otherwise noted.
- Installation carried out strictly in accordance with the product's Installation Instructions and performed by a trained operator.
- Characteristic and design resistances derived from JCP internal technical data.
- Design resistances are calculated from characteristic values using the appropriate partial safety factors corresponding to the decisive failure mode.
- The Recommended Resistance is calculated using an additional safety factor (γ_{Add}) equal to 1.4.
- Performance data is valid for shear loading without a lever arm; installations involving a lever arm require additional verifications.
- Performance data is not valid for combined tensile and shear loading; where combined loading occurs, further checks shall be performed.
- When concrete-related strength factors are applied, ensure that the resulting resistance value does not exceed the steel design resistance.
- For project-specific assessments or conditions not explicitly covered, download the JCP Anchor Calculation Program.



For variations in structure thickness, reduced spacing and edge calculations download the free **Anchor Calculation Program** from www.jcpfixings.co.uk

